

SPECIFICATION FOR APPROVAL

REF. :

PROD. NAME	SMD Power Inductor	ABC'S DWG NO.	SR0602□□□□L□-□□□		
		REV.	20150507-F	PAGE	1

I . Configuration and dimensions :

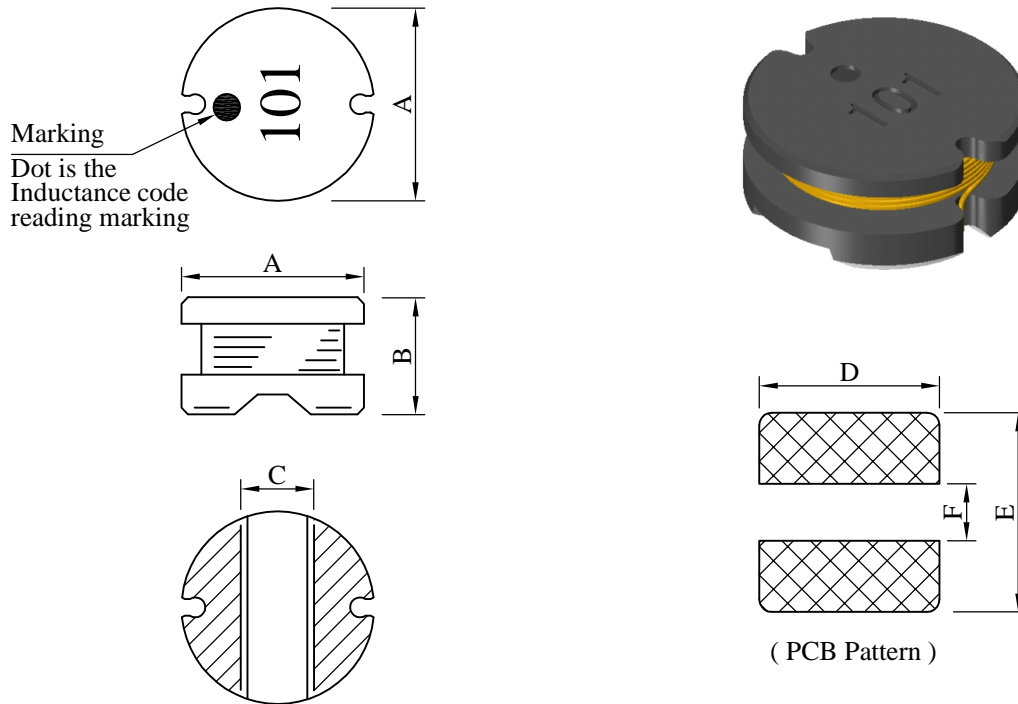

Unit : m/m

A	B	C	D	E	F
5.60 ±0.2	2.50 ±0.3	2.30 ref.	5.80 ref.	6.00 ref.	1.70 ref.

II . Description :

- a . Ferrite drum core construction.
- b . Enamelled copper wire : F 、 H class
- c . Product weight : 0.290g (ref.)
- d . Moisture sensitivity Level 1
- e . Products comply with RoHS' requirements
- f . Halogen free available

III . General specification :

- a . Storage temp. : -40°C ----+125°C
- b . Operating temp. : -40°C ----+125°C
(Temp. rise included)
- c . Resistance to solder heat : 260°C .10 secs.

Peak Temp : 260°C max.
Max. Peak Temp - 5°C : 30sec max.
Max time above 217°C : 60sec~150sec max.

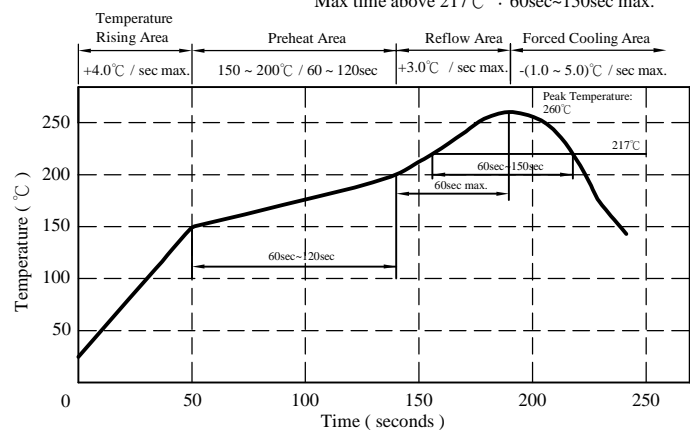

AR-001C

SPECIFICATION FOR APPROVAL

REF. :

PROD. NAME	SMD Power Inductor	ABC'S DWG NO.	SR0602□□□□L□-□□□		
		REV.	20150507-F	PAGE	2

IV . Electrical characteristics :

DWG No.	Inductance (μ H)	Q ref.	Test Freq. (Hz)		SRF (MHz) nom.	RDC (m Ω) max.	Irms (A) max.	Isat (A) typ.
			L	Q				
SR06021R0ML□-□□□	1.0±20%	14	100k	7.960M	90.0	30.0	4.50	4.60
SR06021R4ML□-□□□	1.4±20%	14		7.960M	80.0	35.0	4.00	4.20
SR06021R8ML□-□□□	1.8±20%	13		7.960M	70.0	40.0	3.30	3.50
SR06022R2ML□-□□□	2.2±20%	13		7.960M	60.0	45.0	3.00	3.20
SR06022R7ML□-□□□	2.7±20%	13		7.960M	55.0	50.0	2.80	3.00
SR06023R3ML□-□□□	3.3±20%	12		7.960M	50.0	55.0	2.60	2.90
SR06023R9ML□-□□□	3.9±20%	12		7.960M	45.0	60.0	2.40	2.70
SR06024R7ML□-□□□	4.7±20%	11		7.960M	40.0	70.0	2.20	2.40
SR06025R6ML□-□□□	5.6±20%	11		7.960M	36.0	85.0	2.00	2.30
SR06026R8ML□-□□□	6.8±20%	11		7.960M	32.0	100.0	1.80	2.00
SR06028R2ML□-□□□	8.2±20%	11		7.960M	30.0	110.0	1.60	1.90
SR0602100ML□-□□□	10.0±20%	15		2.520M	26.0	140.0	1.50	1.70
SR0602120ML□-□□□	12.0±20%	15		2.520M	24.0	150.0	1.40	1.60
SR0602150ML□-□□□	15.0±20%	15		2.520M	22.0	180.0	1.30	1.45
SR0602180ML□-□□□	18.0±20%	15		2.520M	20.0	220.0	1.20	1.30
SR0602220ML□-□□□	22.0±20%	15		2.520M	18.0	280.0	1.00	1.10
SR0602270ML□-□□□	27.0±20%	12		2.520M	16.0	320.0	0.90	1.05
SR0602330KL□-□□□	33.0±10%	12		2.520M	15.0	420.0	0.85	1.00
SR0602390KL□-□□□	39.0±10%	12		2.520M	14.0	480.0	0.75	0.80
SR0602470KL□-□□□	47.0±10%	12		2.520M	12.0	560.0	0.73	0.75
SR0602560KL□-□□□	56.0±10%	12		2.520M	11.0	700.0	0.65	0.70
SR0602680KL□-□□□	68.0±10%	12		2.520M	10.0	820.0	0.60	0.65
SR0602820KL□-□□□	82.0±10%	12		2.520M	9.5	1100.0	0.52	0.60
SR0602101KL□-□□□	100.0±10%	22		796k	8.5	1250.0	0.46	0.55
SR0602121KL□-□□□	120.0±10%	22		796k	8.0	1350.0	0.40	0.52
SR0602151KL□-□□□	150.0±10%	22		796k	7.0	1650.0	0.36	0.46
SR0602181KL□-□□□	180.0±10%	24		796k	6.5	1900.0	0.30	0.40
SR0602221KL□-□□□	220.0±10%	24		796k	6.0	2200.0	0.28	0.35
SR0602271KL□-□□□	270.0±10%	24		796k	5.5	3000.0	0.26	0.30
SR0602331KL□-□□□	330.0±10%	34		796k	5.0	3800.0	0.20	0.25
SR0602391KL□-□□□	390.0±10%	34		796k	4.5	4300.0	0.18	0.22
SR0602471KL□-□□□	470.0±10%	36		796k	4.0	5200.0	0.16	0.20
SR0602561KL□-□□□	560.0±10%	36	796k	3.8	6500.0	0.14	0.18	
SR0602681KL□-□□□	680.0±10%	36	796k	3.5	7500.0	0.13	0.16	
SR0602821KL□-□□□	820.0±10%	36	796k	3.0	9800.0	0.10	0.14	
SR0602102KL□-□□□	1000.0±10%	36	252k	2.6	11000.0	0.08	0.12	

- 1). □: Packaging information : □ Code
- 2). "-□□□□": Reference code
- 3). Electrical specifications at 25°C
- 4). Inductance Test Freq. at 100kHz / 0.1V

- 5). Isat base on Δ L/LOA=10% typ.
- 6). Irms base on Temp. rise 40°C max.

AR-001C



SPECIFICATION FOR APPROVAL

REF. :

PROD. NAME	SMD Power Inductor	ABC'S DWG NO.	SR0602□□□□L□-□□□		
		REV.	20150507-F	PAGE	3

V . Curve :

SR06021R0ML□

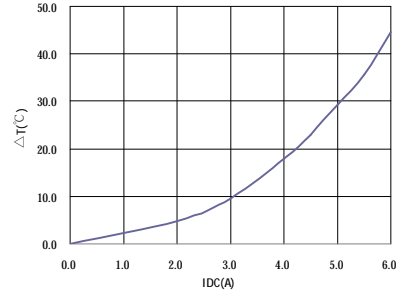
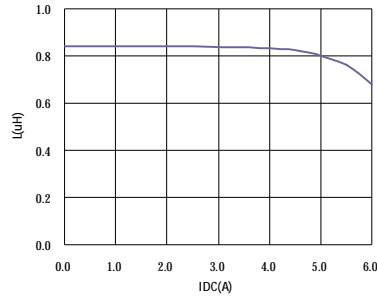

SR0602100ML□

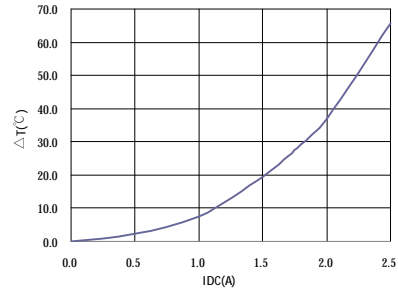
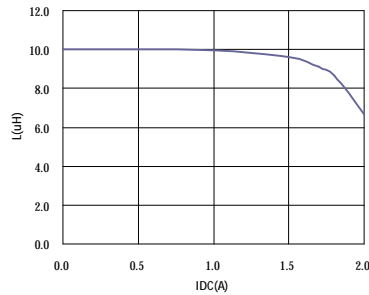

SR0602101KL□

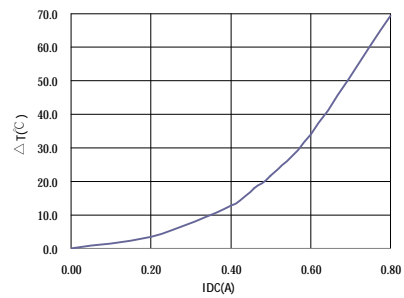
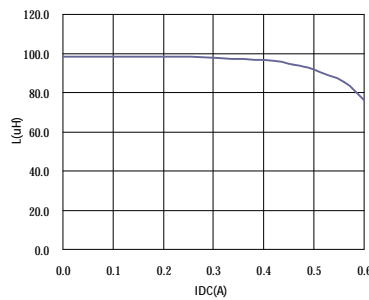

SR0602102KL□

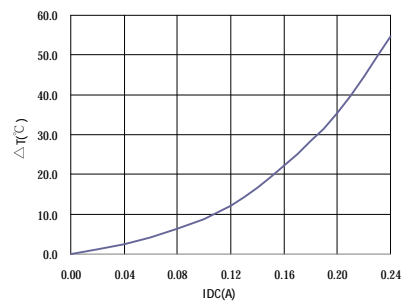
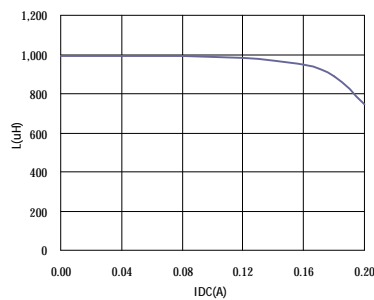

AR-001C

SPECIFICATION FOR APPROVAL

REF. :

PROD. NAME	SMD Power Inductor	ABC'S DWG NO.	SR0602□□□□L□-□□□		
		REV.	20150507-F	PAGE	4

VI . Packaging information :

(1) Configuration

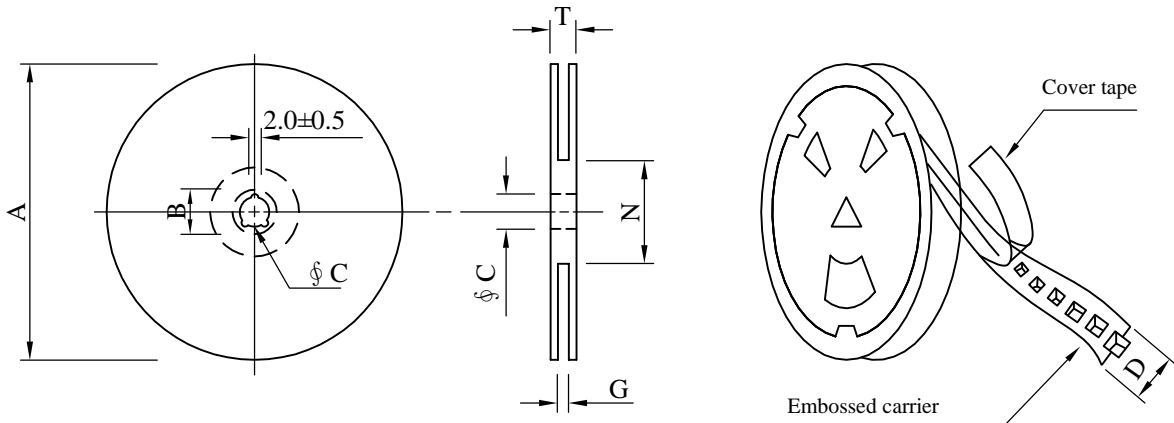

※Carrier tape width : D

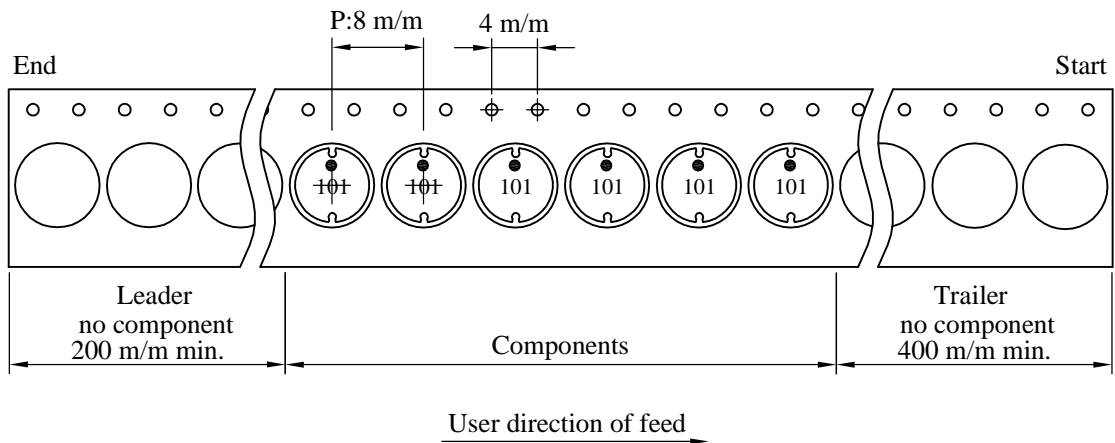

(2) Dimensions

Unit:m/m

Style	A	B	C	D	G	N	T
07 - 12	178	21±0.8	13	12	14 ⁺⁰	50 ⁻⁰	16.5

(3) Q'TY & G.W. Per package

Code	Inner : Reel			Outer : Carton		
	Q'TY (pcs)	G.W. (gw)	Style	Q'TY (pcs)	G.W. (Kg)	Size (cm)
B	700	270	07 - 12	28,000	12.2	42 x 41 x 24

AR-001C

SPECIFICATION FOR APPROVAL

REF. :

PROD. NAME	SMD Power Inductor	ABC'S DWG NO.	SR0602□□□□L□-□□□		
		REV.	20150507-F	PAGE	5

VII . Reliability test :

Item	Reference documents	Test Condition	Test Specification
1.High Temperature Exposure	MIL-STD-202 Method 108	1.Temperature: 125±2℃ 2.Time:96±2 hours.	1.No mechanical or electrical damage. 2.Inductance shall not change more than ±10%.
2.Temperature Cycling	JESD22-A 104	1.Temperature: -40℃ ~ +125℃ 2.Number of cycle:100 cycle 3.Dwell time:30 minutes	1.No mechanical or electrical damage. 2.Inductance shall not change more than ±10%.
3.Biased Humidity Test	MIL-STD-202 Method 103	1.Temperature : 85±2 ℃ 2.Humidity: 85% RH. 3.Time:96±2 Hours	1.No mechanical or electrical damage. 2.Inductance shall not change more than ±10%.
4.Operational Life	JESD22-A 108	1.Temperature: 125℃ (Temp. rise included) 2.Time:96±2 hours. 3.Rated current	1.No mechanical or electrical damage. 2.Inductance shall not change more than ±10%.
5.External Visual	JESD22-B 101 & MIL-STD-883 Method 2009	Inspect product constructions, marking and workmanship.	1.No pollution on the surface of products. 2.Clear marking. 3.No crack.
6.Physical Dimensions	JESD22-B 100	Verify physical dimensions to the applicable product detail specification.	Per product specification standard
7.Resistance to solvents	MIL-STD-202 Method 215	Immerse into solvent for 3±0.5 minutes & brush 10 times for 3 cycles.	1.No body change in apperance. 2.No marking blurred. 3.Inductance shall not change more than ±10%.
8.Vibration Test	MIL-STD-202 Method 204	1.Frequency and Amplitud : 10-2000-10 Hz, 1.5 mm. 2.Direction:X, Y, Z 3.Test duration:2 hours for each direction, 6 hours in total.	1.No mechanical or electrical damage. 2.Inductance shall not change more than ±10%.
9.Resistance To Soldering Heat Test	MIL-STD-202 Method 210 & J-STD020D.1	1.Highest temperature : 260±5℃. 2.Time (temp. ≥ 217℃) : 60~150 Second. 3.IR reflow times : 3 times.	1.No mechanical or electrical damage. 2.Inductance shall not change more than ±10%.
10.Saturation Current	JIS C 6436 & User SPEC.	1.Applied rated current for 5 second. 2.Saturation current	Inductance shall not drop more than 10% typ.
11.Over load	JIS C 6436 & User SPEC.	1.Applied one and half rated current for a period of 5 minutes. 2.Rated current	No electrical or mechanical damage
12.Temperature Rise Current	JIS C 6436 & User SPEC.	1.Applied rated current for 10 minutes. 2.Temperature measure by digital surface thermometer. 3.Irms current	Surface temperature rise is less than 40℃ max.
13.Solderability Test	J-STD-002 & JESD22-B 102	1.Baking in pre-testing : 150±5℃ / 16Hours±30 min. 2.Peak temperature : 240±5℃ 3.Time (temp. ≥ 217℃) : 60~150 second. 4.IR reflow times : 1 times.	More than 95% soldering coverage min on terminations.
14.Electrical Characteriazation	MIL-STD-202 Method 304 & User SPEC.	1.Operating temperature : -40℃~125℃ 2.Room temperature : 25℃.	1.No mechanical or electrical damage. 2.Inductance shall not change more than ±10%.
15.Drop	CNS-C6354 & GB/T 2423.8	1.Products shall be mounted on SPEC. pcb and dropped down from a heigh of 1m 2.Drop total time : 6 time (Every side ofsample drop 2 time)	1. Adhesion on PCB shall be enough. 2. Product appearance shall not break. 3. No electrical damage.
16.Terminal Strength Test	IEC 60068-2-21	1.Apply push force to samples mounted on PCB. 2.Force of 1.8 kg for 60±1 seconds.	After test, inductors shall be no mechanical damage.

AR-001C